

CHAINS FOR THE

FOOD INDUSTRY

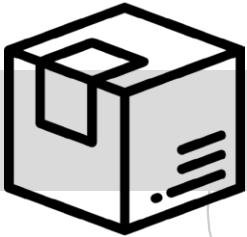

PACKAGING



A UNIQUE KNOW-HOW FROM DESIGN TO PRODUCTION

A HIGH RESISTANCE STAINLESS STEEL

From chocolate to pasta factories, including meat processing or packaging, the food industry is more and more subject to severe constraints : traçability, hygiene.

SEDIS, close to its customers needs, has developed the **Alpha Premium BS INOX** range , which respond particularly well to hygiene constraints of the food industry and offer unequaled productivity gains :

■ **MAINTENANCE REDUCTION TO ENHANCE YOUR PRODUCTIVITY** : the chain has a better wear resistance, offering an extended service life thanks to an innovative technology : 304 grade stainless steel with **increased surface hardness**, solid bushes & extruded rollers.

■ **PRE-LUBRIFICATION DESIGNED FOR FOOD CONTACT** : the chains are pre-lubricated with **certified NSF H1 food wax** : its **direct or accidental contact** with food products is therefore **harmless** (operating temperature from -30 to +140°C : complete *characteristics on request*)

Dry-to-the-touch aspect : no spraying, no et pas de contamination

■ **HIGH BREAKING STRENGTH** : improved **up to 33%** compared to our previous stainless steel range, the breaking loads are up to **20% higher** than the Premium brands of the market.

THE BENEFITS



High
resistance
to wear



Extended
service life



unequaled
breaking
loads



Extended
Protection of
the articulations

Dimensions and technicals data on page 9



**DID YOU
KNOW ?**

The Alpha Premium Stainless steel chain lasts on average **TWICE AS LONG** as a top range stainless steel chain of the market !

The logo features a large, stylized grey letter 'A' with a white outline. Below the 'A', the word "ALPHA" is written in a bold, black, sans-serif font. Underneath "ALPHA", the words "Premium INOX" are written in a smaller, red, sans-serif font. The entire logo is set against a background of faint, light grey circular and wavy lines.

ALPHA
Premium INOX

“ Now a Sedis bestseller, the Alpha Premium BS INOX chain is always upgraded for even more performance and longer service life. ”



THE MOST
RESISTANT
STANDARD STAINLESS STEEL CHAIN
of the market

SPECIFIC SOLUTIONS

DELTA® TITANIUM 2 RANGE

THE ANTI-CORROSION & ANTI-WEAR SOLUTION

From baking ovens to cold storage rooms, including deep-freezing or vegetable washing, some applications require breaking loads higher than stainless steel while having corrosion-resistant properties and a strong resistance to wear for an optimum service life.

The SEDIS range **DELTA® Titanium 2** respond particularly well to these constraints and offer productivity gains :

■ MAINTENANCE REDUCTION FOR AN ENHANCED PRODUCTIVITY :

The chain combines **the high breaking loads** of treated steel and the **resistance to wear** of **DELTA® pins**, with an **anti-corrosion protection**, obtained thanks to the coating applied on the other components. This offers the chain an extended service life, in particular in corrosive and abrasive environments.

■ **ALL TYPES OF ADAPTATIONS POSSIBLE** and **options of lubricants** conform to your application's constraints (high or low temperature, food contact... *refer to the next page*)



THE BENEFITS



Increased
resistance
to corrosion



Extended
Service life



Breaking loads
higher than
stainless steel



unequaled
resistance
to wear

Dimensions and technical data on page 9

? DID YOU KNOW ?

Delta® Titanium chain is an excellent alternative to a stainless steel chain when a high breaking load is required.



SPECIFIC LUBRICANTS & TREATMENTS

Possible on the ranges Alpha Premium, Alpha Premium INOX, Delta® HR, Delta® Titanium 2.



FOOD
CONTACT

FOOD WAX

All Alpha Premium, Delta® HR et DELTA® Titanium chains can be pre-lubricated with food wax on request. All the Alpha Premium BS INOX chains are by default. This wax is required in case of **possible food contamination** by the lubrication, and suits application with a temperature range from **-30°C to +140°C**.



LOW TEMPERATURE

STANDARD WAX

The wax applied by default on our chains Alpha Premium, Alpha Premium BS INOX, DELTA® HR and DELTA® Titanium 2 perfectly suits **low temperatures down to -30°C**, as in the cold rooms.

LOW TEMPERATURE LUBRICANT NSF H1

For applications requiring a food safe lubrication, this lubricant can resist to temperatures **down to -38°C** and is conforming to NSF H1 standard, **harmless in case of contact with food**.

FREEZING TREATMENT

For applications which **temperature goes below -40°C**, or below **-15°C** in the case where the chain is subjected to **important shocks**, components can be treated on request.

This treatment consists in a freezing at **-70°C** followed by a stress free annealing allowing to avoid the pieces embrittlement.

SPECIFIC MATERIAL

For **temperatures below -60°C**, consult us to research the best customized solution.



HIGH TEMPERATURE

STANDARD WAX & OIL

The wax used by default on our chains Alpha Premium BS INOX, Alpha Premium, DELTA® HR and DELTA® Titanium 2 (up to 25,4mm pitch) perfectly suits **high temperatures up to +140°C**. On other steel chains, the initial oil allows operations **up to +200°C**.

NSF H2 HIGH TEMPERATURE

This lubricant suits applications like cooking ovens, where **temperature exceeds 140°C** and **harmless contact with food product** is necessary (NSF H2 standard compliant).

SPECIFIC MATERIAL

For **temperatures above +250°C**, consult us for a customized solution.

BS TRANSMISSION CHAINS

COMPLY WITH ISO 606

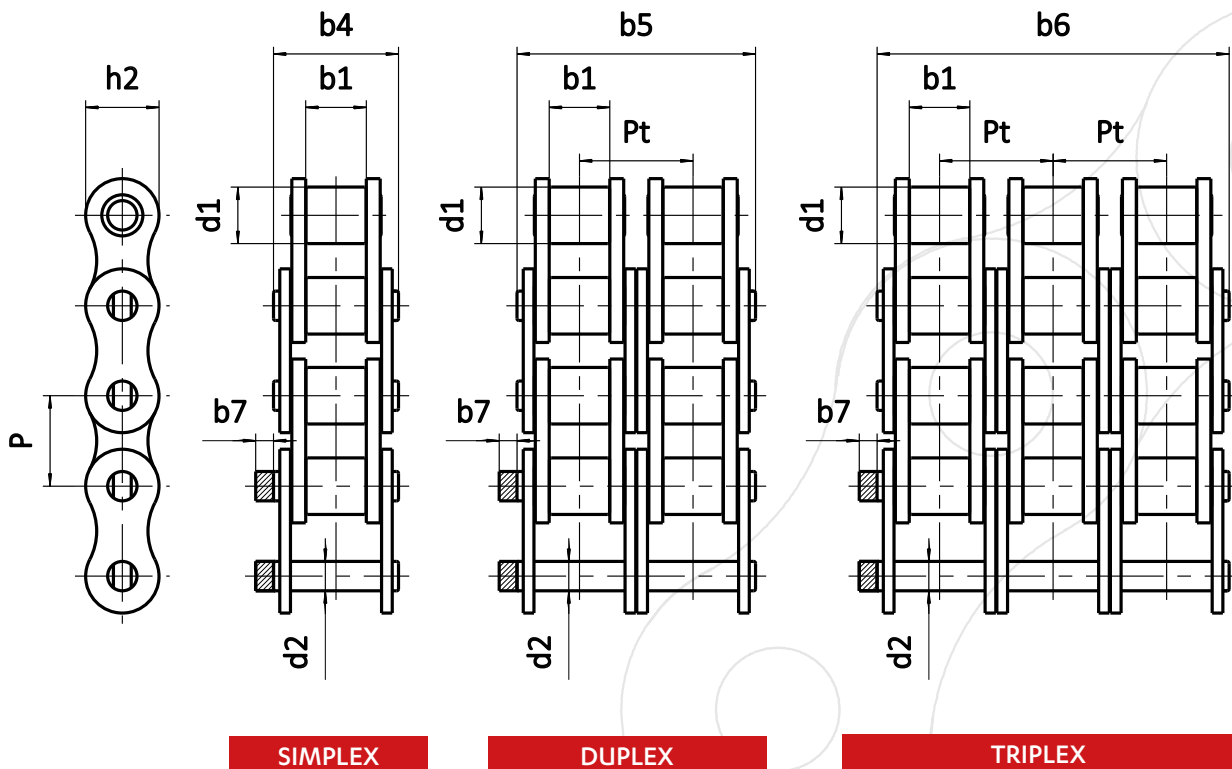

CONNECTING LINKS

CRANKED LINKS

N° 205 link to rivet	N° 206 spring clip connecting link	N° 208 cotted connecting link	N° 209 self locking-nut connecting link	N° 216 cotted cranked link	N° 217 self locking-nut cranked link	N° 221 Double cranked link

SEDIS TRANSMISSION RANGES

Made in France



ALPHA Premium
high quality



ALPHA Premium BS INOX
High résistance
stainless steel



DELTA® HR
wear & abrasion
resistant



DELTA® Titanium 2
anticorrosion



Châînes Vertes
maintenance-free

REFERENCES		RANGES AVAILABILITY						DETAILS (mm)								BREAKING LOAD (kN)					
ISO	SEDIS	ALPHA Premium	ALPHA Premium INOX	DELTA® HR	DELTA® TITANIUM 2	LUBE FREE VERTE	DELTA® VERTE	Pitch P	d1	b1	b4 b5 b6	d2	h2	b7	Pt	ISO 606 standard	ALPHA Premium	ALPHA Premium INOX	DELTA® HR / TITANIUM 2	LUBE FREE VERTE	DELTA® VERTE
									max.	min.	max.	max.	max.	max.	min.						
SIMPLEX																					
06B-1	3N	x	x	x	x			9,525	6,35	5,77	13,50	3,27	8,23	2,1	.	8,9	8,9	6,3	9,0	.	.
08B-1	7N	x	x	x	x	x	x	12,7	8,51	7,75	16,60	4,45	11,80	1,5	.	17,8	18,2	14	18,2	18,2	16,6
10B-1	11N	x	x	x	x	x	x	15,875	10,16	9,65	19,00	5,08	13,70	1,5	.	22,2	23	17,6	23	23	18,6
12B-1	13N	x	x	x	x	x	x	19,05	12,07	11,68	22,30	5,72	16,20	1,5	.	28,9	30,5	21	30,5	30,5	30,5
16B-1	15T	x	x	x	x	x	x	25,4	15,88	17,02	35,10	8,28	20,80	3,0	.	60	66	43	75	66	66
20B-1	17T	x		x	x		x*	31,75	19,05	19,56	40,50	10,19	25,40	6,1	.	95	105	46	110	.	99
24B-1	18T	x		x	x		x*	38,1	25,40	25,40	53,10	14,63	32,30	6,6	.	160	180	81	180	.	160
28B-1	20T	x		x	x		x*	44,45	27,94	30,95	65,10	15,90	37,00	7,4	.	200	235	.	235	.	180
32B-1	22T	x		x	x		x	50,8	29,21	30,99	63,60	17,81	42,30	7,9	.	250	270	.	300	.	250
40B-1	23T	x		x	x		x	63,5	39,37	38,10	79,00	22,89	52,80	12,0	.	355	365	.	365	.	365
48B-1	24T	x		x	x			76,2	48,26	47,70	98,60	29,22	64,20	23,7	.	560	600	.	600	.	.
DUPLEX																					
06B-2	203N	x	x					9,525	6,35	5,77	23,80	3,28	8,23	2,1	10,24	16,9	16,9	9,8	17,6	.	.
08B-2	207N	x	x	x	x	x	x	12,7	8,51	7,75	30,60	4,45	11,80	1,5	13,92	31,1	36,4	28	36,4	36,4	33,2
10B-2	211N	x	x	x	x	x	x	15,875	10,16	9,65	35,75	5,08	13,70	1,5	16,59	44,5	46	35,2	46	46	37,2
12B-2	213N	x	x	x	x	x	x	19,05	12,07	11,68	41,80	5,72	16,20	1,5	19,46	57,8	61	42	61	61	61
16B-2	215T	x	x	x	x	x	x	25,4	15,88	17,02	68,00	8,28	20,80	3,0	31,88	106	132	86	150	132	132
20B-2	217T	x		x	x		x*	31,75	19,05	19,56	77,00	10,19	25,40	6,1	36,45	170	210	92	220	.	198
24B-2	218T	x		x	x		x*	38,1	25,40	25,40	101,80	14,63	32,30	6,6	48,36	280	360	162	360	.	320
28B-2	220T	x		x	x		x*	44,45	27,94	30,95	124,70	15,90	37,00	7,4	59,56	360	470	.	470	.	360
32B-2	222T	x		x	x		x	50,8	29,21	30,99	122,80	17,81	42,30	7,9	58,55	450	540	.	600	.	500
40B-2	223T	x		x	x		x	63,5	39,37	38,10	152,00	22,89	52,80	12,0	72,29	630	730	.	730	.	730
48B-2	224T	x		x	x			76,2	48,26	47,70	190,40	29,22	64,20	23,7	91,21	1 000	1 200	.	1 200	.	.
TRIPLEX																					
06B-3	303N	x						9,525	6,35	5,77	34,00	3,28	8,23	2,1	10,24	24,9	24,9	.	26,4	.	.
08B-3	307N	x	x	x	x	x	x	12,7	8,51	7,75	44,60	4,45	11,80	1,5	13,92	44,5	54,6	42	54,6	54,6	49,8
10B-3	311N	x	x	x	x	x	x	15,875	10,16	9,65	52,30	5,08	13,70	1,5	16,59	66,7	69	52,8	69	69	55,8
12B-3	313N	x	x	x	x	x	x	19,05	12,07	11,68	61,40	5,72	16,20	1,5	19,46	86,7	91,5	63	91,5	91,5	91,5
16B-3	315T	x	x	x	x	x	x	25,4	15,88	17,02	99,90	8,28	20,80	3,0	31,88	160	198	129	225	198	198
20B-3	317T	x		x	x		x*	31,75	19,05	19,56	113,50	10,19	25,40	6,1	36,45	250	315	138	330	.	297
24B-3	318T	x		x	x		x*	38,1	25,40	25,40	150,20	14,63	32,30	6,6	48,36	425	540	243	540	.	480
28B-3	320T	x		x	x		x*	44,45	27,94	30,95	184,60	15,90	37,00	7,4	59,56	530	705	.	705	.	540
32B-3	322T	x		x	x		x	50,8	29,21	30,99	181,70	17,81	42,30	7,9	58,55	670	810	.	900	.	750
40B-3	323T	x		x	x		x	63,5	39,37	38,10	224,60	22,89	52,80	12,0	72,29	950	1 095	.	1 095	.	1 095
48B-3	324T	x		x	x			76,2	48,26	47,70	281,60	29,22	64,20	23,7	91,21	1 500	1 800	.	1 800	.	.

* The pin diameter and the working surface are different . Consult us for more details.
For Verte chains, the use of sprockets with treated teeth is recommended.



ASA standard chains
also available
consult our catalogue

ADAPTED TRANSMISSION CHAINS

COMPLY WITH ISO 606

STRAIGHT SIDE PLATES

These chains work by sliding on a guide or carry loads (palets, cardboards) directly on the plates.

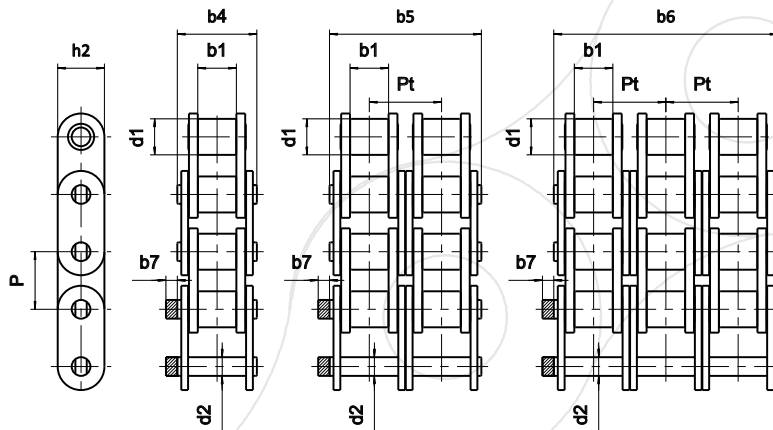

References				Pitch P	ranges availability					d1	b1	b4	b5	b6	d2	h2	Pt	b7
ISO	SEDIS				ALPHA Premium	ALPHA Premium INOX	DELTA® HR	DELTA Titanium 2	CHAINES VERTES									
	simplex	duplex	triplex							simplex	duplex	triplex						
-	2ND	-	-	9,525			✓			6,35	4,10	10,25	-	-	3,28	8,2	-	2,1
06B-1	3N	203N	303N	9,525	✓	✓	✓	✓		6,35	5,77	12,50	23,10	33,00	3,28	8,2	10,24	2,1
08B-1	7NNE	207NNE	307NNE	12,7	✓	✓	✓	✓	(1)	8,51	7,75	16,60	30,60	44,60	4,45	11,8	13,92	1,5
10B-1	11NNE	211NNE	311NNE	15,875	✓	✓	✓	✓	(1)	10,16	9,65	19,00	35,75	52,30	5,08	13,7	16,59	1,5
12B-1	13NNE	213NNE	313NNE	19,05	✓	✓	✓	✓	(1)	12,07	11,68	22,30	41,80	61,40	5,72	16,2	19,46	1,5
16B-1	15TNE	215TNE	315TNE	25,4	✓	✓	✓	✓	(1)	15,88	17,02	35,10	68,00	99,90	8,28	20,8	31,88	3,0
20B-1	17TNE	217TNE	317TNE	31,75	✓	✓	✓	✓	(2)	19,05	19,56	40,50	79,70	116,10	10,19	25,4	36,45	8,5
24B-1	18TNE	218TNE	318TNE	38,1	✓	✓	✓	✓	(2)	25,40	25,40	53,10	101,80	150,20	14,63	33,4	48,36	8,5
32B-1	22TNE	222TNE	322TNE	50,8	✓		✓	✓	(2)	29,10	30,95	63,60	121,60	179,80	17,81	42,3	58,55	10,4

(1) : References in Lub Free. In DELTA® VERTE please consult us (2) : Only available in DELTA® VERTE

HOLLOW BEARING PIN

Used on conveyors using two chains in parallel, connected by bars.

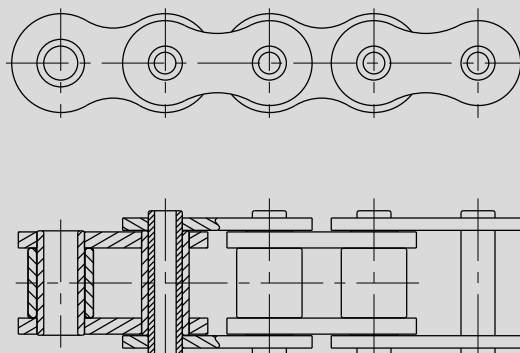

References		Pitch p	ranges availability		d1 max	d4 max	b1 min	b4 max	d2 max	d6 min	h2 max	Nominal bearing surface mm²	Breaking load (kN)	
ISO	SEDIS		ALPHA Premium	Stainless steel									ALPHA Premium min	Stainless steel min
08B-1	7C40	12,7	✓		8,51		7,75	16,50	6,55	4,00	11,80	73	11,1	
08B-1	7C45	12,7	✓		8,51		7,75	16,50	6,55	4,50	11,80	73	11,1	
12B-1	13C	19,05	✓		12,07		11,68	23,00	8,25	6,10	18,30	128	24,0	
16A-1	80C	25,4	✓		15,88		15,87	32,60	11,58	8,05	24,00	260	41,2	
	A55BC	41,75	✓	✓		17,10	19,90	35,70	11,11	8,20	21,65	292	26,5	17,6
	A155TS	41,75	✓			17,10	19,90	35,70	11,11	8,20	25,26	292	49,0	



The adapted chains in red can be

DESPATCHED WITHIN 48H

50 meters maximum. Consult us.



CHAINS FOR THE FOOD INDUSTRY

EXTENDED BEARING PINS

Chains for light conveyors or for roller conveyors (bulk conveying, chocolate, beverage cans). The pins can be off-set (on one side), symmetrical or alternated (on both sides)

Possible on duplex and triplex chains

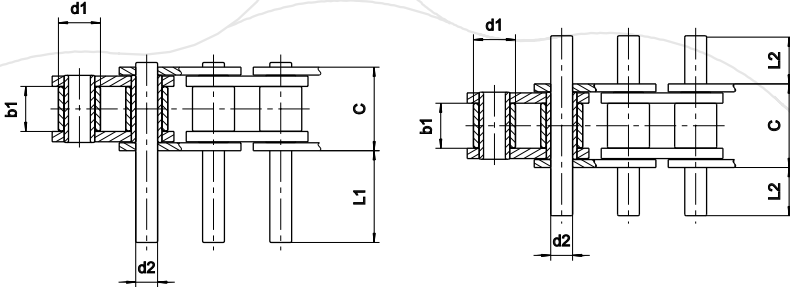

References		Pitch P	ranges availability				CHAINES VERTES	d1	b1	C	d2	L1										L2									
ISO	SEDIS		ALPHA Premium	ALPHA Premium INOX	DELTA® HR	DELTA Titanium 2						11,1	12,7	14,3	15,8	17,2	18,7	20,9	21,7	21,5	25,4	34,4	54,4	74,9	194	5,8	6,0	7,9	11,0	12,9	17,7
06B-1	3N	9,525	✓		✓	✓	6,35	5,77	11,01	3,28	11,1	12,7	14,3	15,8	17,2	18,7	20,9	21,7	21,5	25,4	34,4	54,4	74,9	194	5,8	6,0	7,9	11,0	12,9	17,7	20,0
08B-1	7N	12,7	✓		✓	✓	8,51	7,75	14,43	4,45	3,5	4,3	5,2	6,2	7,2	8,2	9,2	10,2	11,2	12,2	13,2	14,2	15,2	16,2	17,2	18,2	19,2	20,2	21,2	22,2	23,2
10B-1	11N	15,875	✓	✓	✓	✓	10,16	9,65	16,95	5,08	4,3	5,2	6,2	7,2	8,2	9,2	10,2	11,2	12,2	13,2	14,2	15,2	16,2	17,2	18,2	19,2	20,2	21,2	22,2	23,2	24,2
12B-1	13N	19,05	✓	✓	✓	✓	12,07	11,65	19,75	5,72	10,4	11,4	12,4	13,4	14,4	15,4	16,4	17,4	18,4	19,4	20,4	21,4	22,4	23,4	24,4	25,4	26,4	27,4	28,4	29,4	
16B-1	15T	25,4	✓	✓	✓	✓	15,88	17,02	32,09	8,28	8,7	9,7	10,7	11,7	12,7	13,7	14,7	15,7	16,7	17,7	18,7	19,7	20,7	21,7	22,7	23,7	24,7	25,7	26,7	27,7	
20B-1	17T	31,75	✓	✓	✓	✓	19,05	19,56	36,80	10,19	6,6	7,6	8,6	9,6	10,6	11,6	12,6	13,6	14,6	15,6	16,6	17,6	18,6	19,6	20,6	21,6	22,6	23,6	24,6	25,6	
24B-1	18T	38,1	✓	✓	✓	✓	25,40	25,40	48,72	14,63	11,7	12,7	13,7	14,7	15,7	16,7	17,7	18,7	19,7	20,7	21,7	22,7	23,7	24,7	25,7	26,7	27,7	28,7	29,7	30,7	
28B-1	20T	44,45	✓	✓	✓	✓	27,94	30,95	60,00	15,90	22,0	23,0	24,0	25,0	26,0	27,0	28,0	29,0	30,0	31,0	32,0	33,0	34,0	35,0	36,0	37,0	38,0	39,0	40,0	41,0	
32B-1	22T	50,8	✓	✓	✓	✓	29,21	30,95	58,62	17,81	19,5	20,5	21,5	22,5	23,5	24,5	25,5	26,5	27,5	28,5	29,5	30,5	31,5	32,5	33,5	34,5	35,5	36,5	37,5	38,5	
40B-1	23T	63,5	✓	✓	✓	✓	39,37	38,10	72,70	22,89	30,0	31,0	32,0	33,0	34,0	35,0	36,0	37,0	38,0	39,0	40,0	41,0	42,0	43,0	44,0	45,0	46,0	47,0	48,0	49,0	
48B-1	24T	76,2	✓	✓	✓	✓	48,26	47,70	91,40	29,22	35,5	36,5	37,5	38,5	39,5	40,5	41,5	42,5	43,5	44,5	45,5	46,5	47,5	48,5	49,5	50,5	51,5	52,5	53,5	54,5	

(1) : References in Lub Free. In DELTA® VERTE please consult us (2) : Only available in DELTA® VERTE * Pin diameter is different. Consult us.

Other dimensions possible on request

SPECIAL EXTENDED PINS

PINS WITH CIRCLIP GROOVE

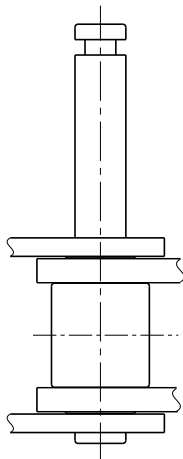

THREADED PINS

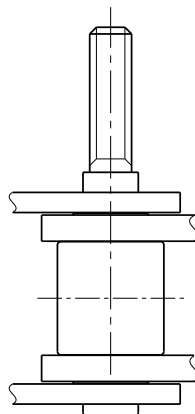

COTTERED PINS

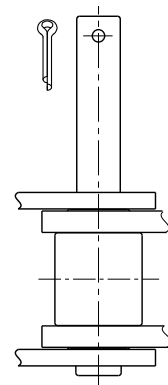

ADAPTED TRANSMISSION CHAINS

COMPLY WITH ISO 606

K ATTACHMENTS



These chains are used in light conveying using two chains in parallel. The plates can have one or several holes and be short or long.

Possible on duplex and triplex chains

TYPES OF K ATTACHMENTS

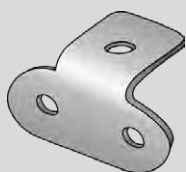

SHORT plates

comply with ISO 606
(reference : C)

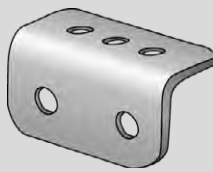

LONG plates

comply with ISO 606
(reference : L)

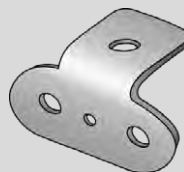

TYPE B plates

Additional hole on the low part of the plate, comply with British standards

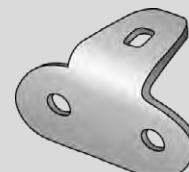

TYPE Z plates

Long hole to adjust fixing

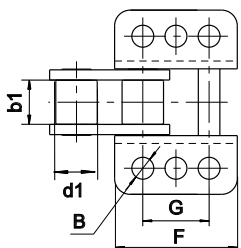
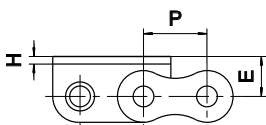
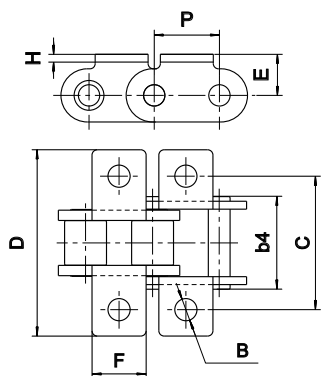

References		Pitch P	ranges availability					d1	b1	b4	B	C	D		E	F	G	H	
ISO	sedis		Alpha Premium	Alpha Premium INOX	Delta HR	Delta Titanium	Chaines Vertes						on inner link	on outer link				on inner link	on outer link
K1C attachments																			
06B-1	3N	9,525	✓		✓	✓		6,35	5,77	12,50	3,10	19,85	x	29,05	6,55	8,30	-	x	1,0
08B-1	7N	12,7	✓		✓	✓	(1)	8,51	7,75	16,60	4,30	25,40	35,55	37,95	9,20	10,70	-	1,6	1,3
10B-1	11N	15,875	✓		✓	✓	(1)	10,16	9,65	19,0	5,30	31,75	42,65	46,65	10,60	13,80	-	1,6	1,6
12B-1	13N	19,05	✓		✓	✓	(1)	12,07	11,68	22,30	7,12	38,10	57,0	61,0	13,80	16,50	-	1,8	1,8
16B-1	15T	25,4	✓	✓	✓	✓	(1)	15,88	17,02	35,10	8,40	50,80	74,0	74,0	16,15	20,76	-	3,9	3
20B-1	17T	31,75	✓		✓	✓		19,05	19,56	40,50	8,40	63,50	96,0	96,0	20,10	25,76	-	4,5	3,5
*	18T	38,1	✓		✓	✓		25,40	25,40	53,10	11,0	88,0	x	129,0	25,0	38,0	-	x	5
K1L attachments																			
06B-1	3N	9,525	✓		✓	✓		6,35	5,77	12,50	3,10	19,85	x	29,05	6,55	17,70	-	x	1,0
08B-1	7N	12,7	✓		✓	✓	(1)	8,51	7,75	16,60	4,30	25,40	x	37,95	9,20	24,50	-	x	1,30
10B-1	11N	15,875	✓		✓	✓	(1)	10,16	9,65	19,0	5,30	31,75	x	46,65	10,60	29,50	-	x	1,60
12B-1	13N	19,05	✓		✓	✓	(1)	12,07	11,68	22,30	-	-	x	Utiliser des K3L		-	x	-	
16B-1	15T	25,4	✓	✓	✓	✓	(1)	15,88	17,02	35,10	8,40	50,80	74,0	74,0	16,15	47,20	-	3,90	3,0
K2L attachments																			
06B-1	3N	9,525	✓		✓	✓		6,35	5,77	12,50	3,10	19,85	x	29,05	6,55	17,70	9,50	x	1,0
08B-1	7N	12,7	✓		✓	✓	(1)	8,51	7,75	16,60	4,30	25,40	35,55	37,95	9,20	24,50	12,70	1,30	1,30
10B-1	11N	15,875	✓	✓	✓	✓	(1)	10,16	9,65	19,0	5,30	31,75	42,65	46,65	10,60	29,50	15,88	1,60	1,60
12B-1	13N	19,05	✓		✓	✓	(1)	12,07	11,68	22,30	-	-	x	Utiliser des K3L		-	x	-	
16B-1	15T	25,4	✓	✓	✓	✓	(1)	15,88	17,02	35,10	8,40	50,80	74,0	74,0	16,15	47,20	25,40	3,90	3,0
*	17T	31,75	✓		✓	✓		19,05	19,56	40,50	10,40	69,0	100,0	100,0	21,0	57,50	31,70	3,50	3,50
*	18T	38,1	✓		✓	✓		25,40	25,40	53,10	12,40	88,0	x	126,0	28,0	72,0	38,10	x	5,0
28B-1	20T	44,45	✓		✓	✓		27,94	30,99	65,10	13,50	88,90	x	125,0	28,90	79,60	45,0	x	6,35
K3L attachments																			
12B-1	13N	19,05	✓	✓	✓	✓		12,07	11,68	22,30	6,40	38,10	x	61,0	13,80	35,10	19,05	x	1,80
16B-1	15T	25,4	✓	✓	✓	✓		15,88	17,02	35,10	8,40	50,80	74,0	74,0	16,15	47,20	25,40	3,90	3,0
*	17T	31,75	✓		✓	✓		19,05	19,56	40,50	8,4	63,5	x	94	20,2	58,2	31,75	x	3,5

* Attachment dimensions do not comply with standards

(1) References in Lub Free. In DELTA® VERTE please consult us.



The adapted chains **in red** can be

DESPATCHED WITHIN 48H

50 meters maximum. Consult us.



CHAINS FOR THE FOOD INDUSTRY

M ATTACHMENTS



These chains are used in light conveying using two chains in parallel. The plates can have one or several holes and be short or long.

Possible on duplex and triplex chains

TYPES OF M ATTACHMENTS



SHORT plates

comply with ISO 606
(reference : C)

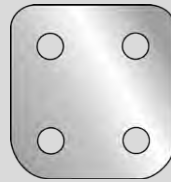

LONG plates

comply with ISO 606
(reference : L)

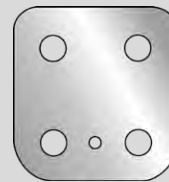

TYPE B plates

Additional hole on the low part of the plate, comply with British standards

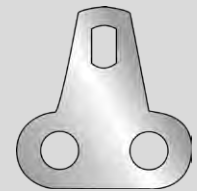

TYPE Z plates

Long hole to adjust fixing

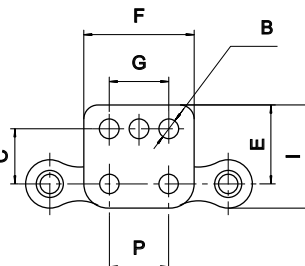
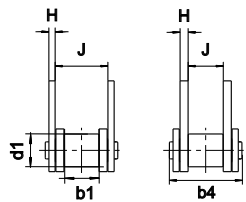
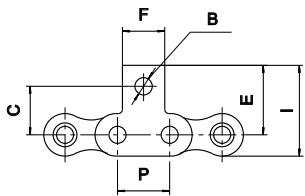

References		Pitch P	ranges availability				d1	b1	b4	B	C	E	F	G	H		I		J		
ISO	sedis		Alpha Premium	Alpha Premium INOX	Delta HR	Delta Titanium									Chânes Vertes	on inner link	on outer link	on inner link	on outer link	on inner link	on outer link
M1C attachments																					
06B-1	3N	9,525	✓		✓	✓	(1)	6,36	5,77	12,50	3,10	10,0	14,60	8,30	-	x	1,0	x	18,70	x	8,63
08B-1	7N	12,7	✓		✓	✓	(1)	8,51	7,75	16,60	4,30	13,80	20,0	10,70	-	1,6	1,3	26,10	26,10	7,75	11,45
10B-1	11N	15,875	✓		✓	✓	(1)	10,16	9,65	19,0	5,30	16,60	24,0	13,80	-	1,6	1,6	31,05	31,05	9,65	13,30
12B-1	13N	19,05	✓	✓	✓	✓	(1)	12,07	11,68	22,30	7,12	22,20	32,45	16,50	-	1,8	1,8	40,75	40,75	11,68	15,75
16B-1	15T	25,4	✓	✓	✓	✓	(1)	15,88	17,02	35,10	8,40	23,50	33,65	20,76	-	3,9	3,0	47,30	44,15	17,02	25,58
20B-1	17T	31,75	✓		✓	✓		19,05	19,56	40,50	8,40	31,75	46,0	25,76	-	x	3,5	x	58,83	x	29,14
M1L attachments																					
06B-1	3N	9,525	✓		✓	✓	(1)	6,35	5,77	12,50	3,10	10,0	14,60	17,70	-	x	1,0	x	18,70	x	8,63
08B-1	7N	12,7	✓		✓	✓	(1)	8,51	7,75	16,60	4,30	13,80	20,0	24,50	-	1,60	1,30	26,10	26,10	7,75	11,45
10B-1	11N	15,875	✓		✓	✓	(1)	10,16	9,65	19,0	5,30	16,60	24,0	29,50	-	x	1,60	x	31,05	x	13,30
12B-1	13N	19,05	✓		✓	✓	(1)	12,07	11,68	22,30	utiliser des M3L				x	utiliser des M3L					
16B-1	15T	25,4	✓	✓	✓	✓	(1)	15,88	17,02	35,10	8,40	23,50	33,65		-	3,90	3,0	47,30	44,15	17,02	25,58
M2L attachments																					
06B-1	3N	9,525	✓		✓	✓	(1)	6,35	5,77	12,50	3,10	10,0	14,60	17,70	9,50	x	1,0	x	18,70	x	8,63
08B-1	7N	12,7	✓		✓	✓	(1)	8,51	7,75	16,60	4,30	13,80	20,0	24,50	12,70	1,30	1,30	26,10	26,10	7,75	11,45
10B-1	11N	15,875	✓	✓	✓	✓	(1)	10,16	9,65	19,0	5,30	16,60	24,0	29,50	15,88	x	1,60	x	31,05	x	13,30
12B-1	13N	19,05	✓		✓	✓	(1)	12,07	11,68	22,30	utiliser des M3L				x	utiliser des M3L					
16B-1	15T	25,4	✓	✓	✓	✓	(1)	15,88	17,02	35,10	8,40	23,50	33,65	47,20	25,40	3,90	3,0	47,30	44,45	17,02	25,58
M3L attachments																					
12B-1	13N	19,05	✓	✓	✓	✓		12,07	11,68	22,30	6,40	21,20	32,45	35,10	19,05	x	1,80	x	40,75	x	15,75
16B-1	15T	25,4	✓	✓	✓	✓		15,88	17,02	35,10	8,40	23,50	33,65	47,20	25,40	3,90	3,0	47,30	44,15	17,02	25,58

(1) References in Lub Free. In DELTA® VERTE please consult us.

Other types of attachments and dimensions possible on request

WHEELS, SPROCKETS & COMPONENTS

STANDARD WHEELS & SPROCKETS

comply with ISO 606

Simplex, duplex and triplex wheels & sprockets can be bored, with taper -lock ou ready to mount, in steel or stainless steel.

See our Industrial components catalogue

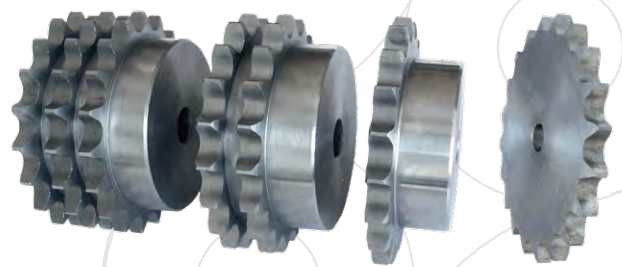

SPECIAL WHEELS, SPROCKETS AND SHAFTS

Many products are possible : sectors sprockets, spline sprockets, with shafts... in steel, stanless steel or treated steel.

Consult us



EXAMPLE OF SPECIAL PRODUCT

20 TEETH SPECIAL WHEEL - BAKERY (HAMBURGER BREAD)

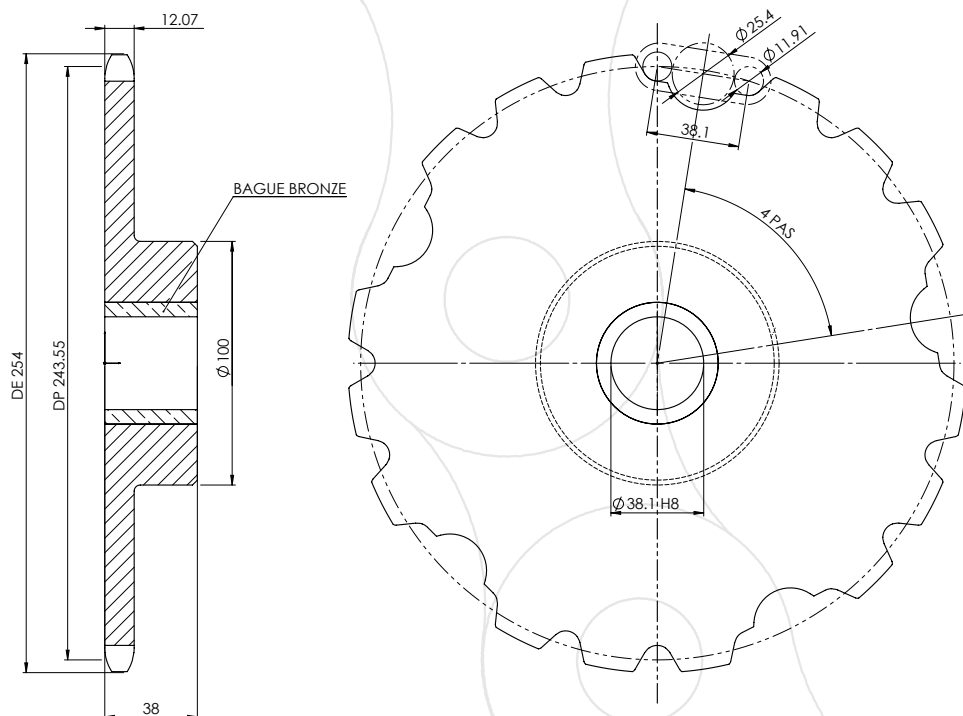

ACCESSORIES



CHAIN WEAR GAUGE

To simply measure elongation of **leaf chains** and simplex, duplex and triplex **roller chains** of pitches from 9,525 (3/8") to 44,45mm (1.3/4")

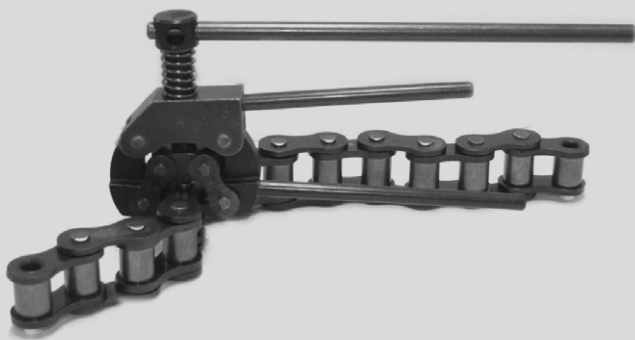

PIN EXTRACTORS

Two references to cut chains easily:

- **9130** : for simplex, duplex and triplex chains of pitches from 8 to 19,05mm
- **9160** : for simplex, duplex and triplex chains of pitches from 25,4 to 31,75mm

INDUSTRIAL COMPONENTS



WEAR STRIPS, TENSIONERS, PULLEYS, TIMING BARS, GEARS & RACKS, BEVEL GEAR PAIRS, COUPLINGS, CLAMPING BUSHES...

Consult our Industrial Components catalogue

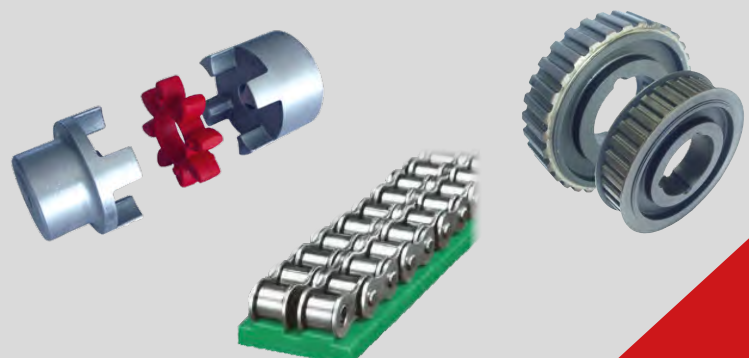

Download it on
WWW.SEDIS.COM/
DOWNLOADS

CHAINS FOR PACKAGING PROCESS

CHAINS FOR THERMOFORMING MACHINES

SPIKED CHAINS FOR THERMOFORMING MACHINES

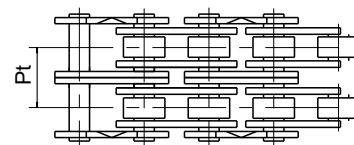
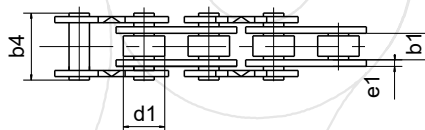
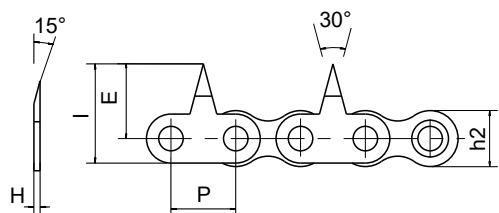

REFERENCES		RANGE AVAILABILITY				DIMENSIONS (mm)										
ISO	SEDIS	ALPHA Premium	DELTA® HR	DELTA® TITANIUM 2	CHAÎNES VERTES	Pas P	d1	b1	b4	Pt (duplex version)	e1	e2	E	F	G	H
						max.	min.									
TYPE B CHAINS (European standard)																
08B-1	7N	x	x	x	x	12,7	8,51	7,75	16,60	13,92	1,6	1,5	14,5	20,4	11,8	5,9
10B-1	11N	x	x	x	x	15,875	10,16	9,65	19,00	16,59	1,6	1,5	16	22,2	13,7	6
TYPE B NARROW CHAINS (European standard)																
-	6N	x	x	x		12,7	8,51	5,35	14,10	-	1,6	1,5	14,5	20,4	11,8	5,9
-	10N	x	x	x		15,875	10,16	6,50	16,60	-	1,6	1,5	16	22,2	13,7	6
TYPE A CHAINS (American standard)																
08A-1	40-1	x	x	x		12,7	7,93	7,85	16,30	14,38	1,6	1,5	14,5	20,4	11,5	5,9
10A-1	50-1	x	x	x		15,875	10,16	9,65	20,85	18,11	2,0	2,0	16,4	23,2	13,7	6,8

Any spike height possible on request

GRIPPER CHAINS FOR THERMOFORMING MACHINES

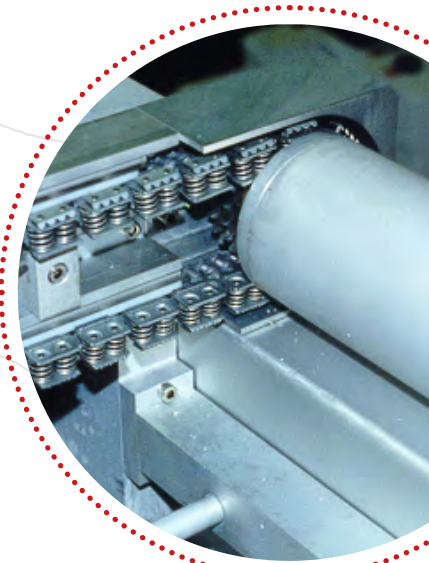
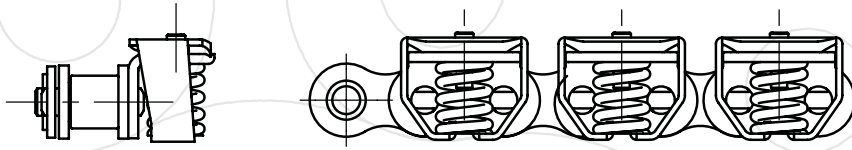

- 12,7mm and 15,875mm pitch chains
- Springs with resistance of 50 or 100N possible
- Stainless steel grips in straight version (1) or heart-shaped (2)
- Chains in nickel-plated or Delta® Titanium 2 versions possible

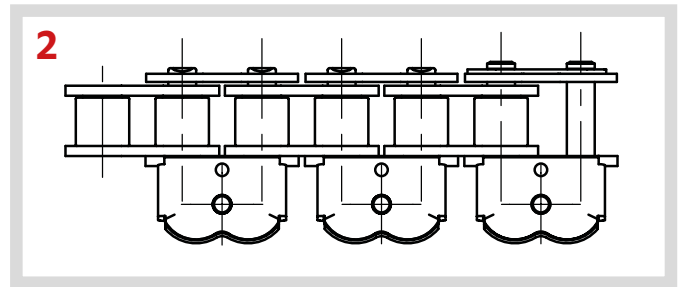
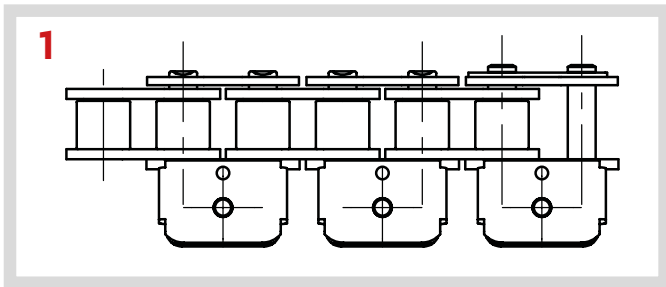

EXAMPLES OF SPECIAL PRODUCTS

CHAINS WITH THREADED INSERTS FOR CHOCOLATE PACKAGING

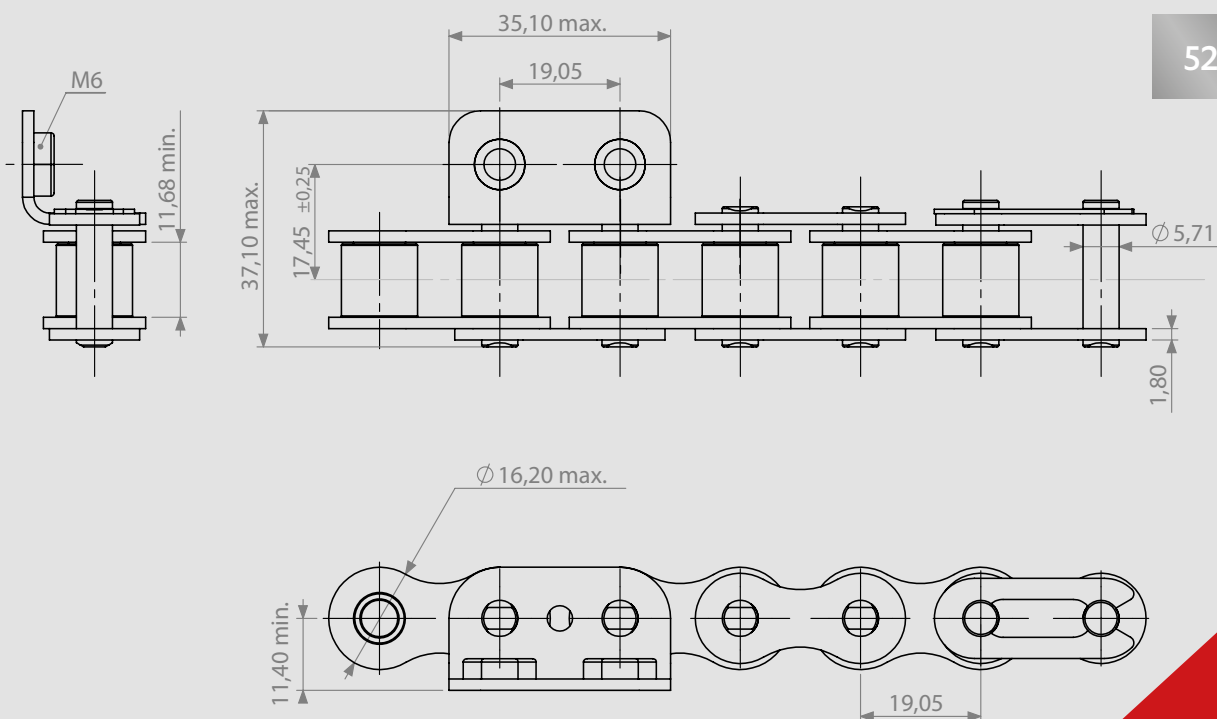

5248-48

CHAINS FOR PACKAGING PROCESS

CHAIN WITH THREADED PINS FOR CARTONING MACHINE

5086-47

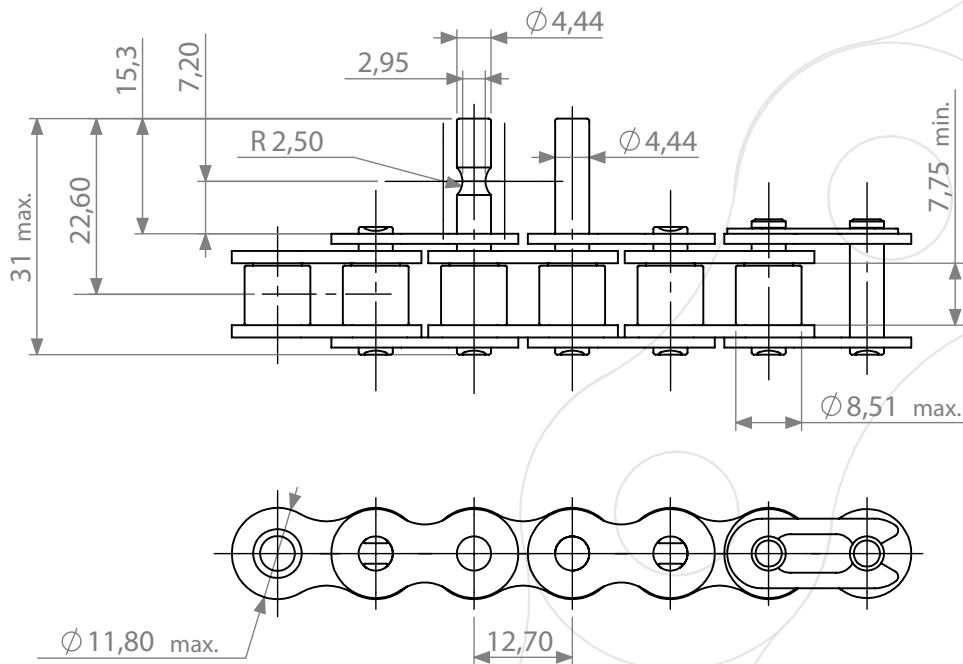

CHAIN FOR FRUIT JUICE PACKAGING

5139-70

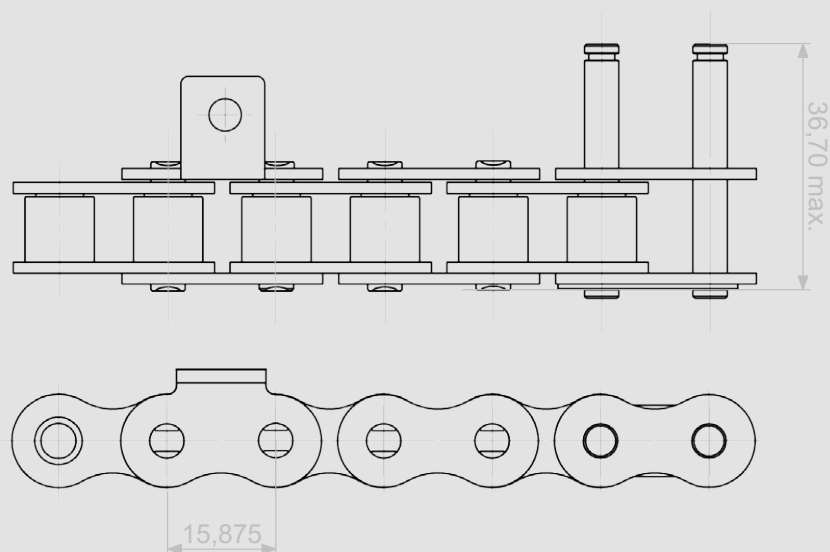

SPECIAL SPIKED CHAINS

5085-33

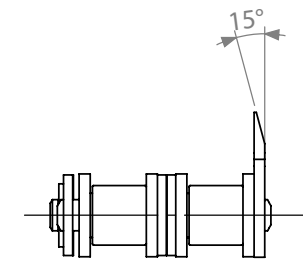
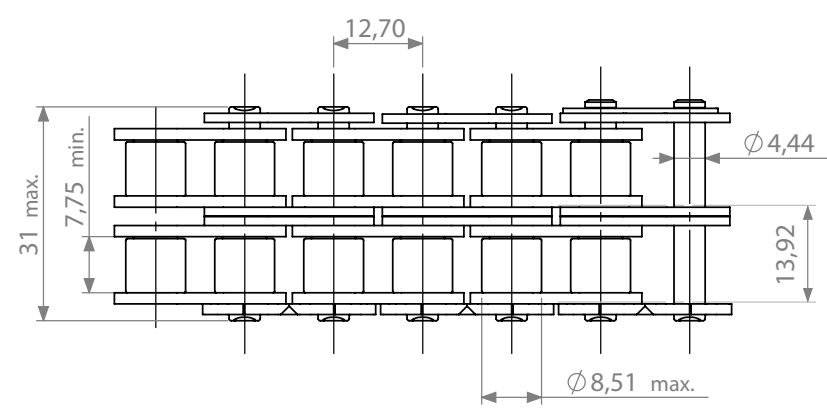
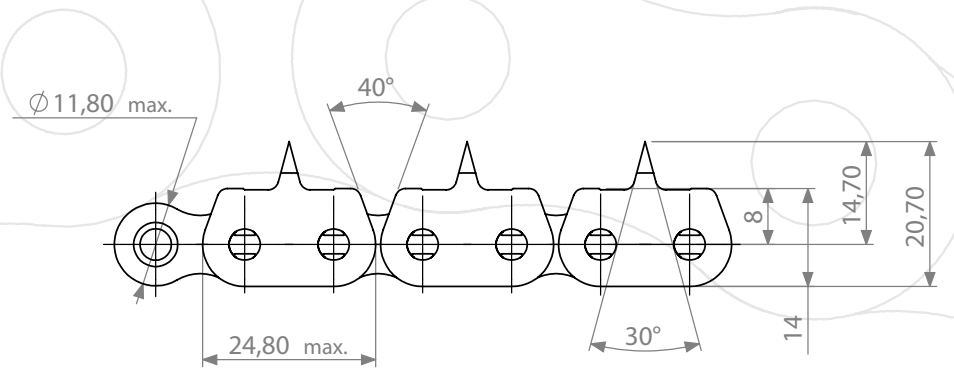

5083-82

