

Sedis : una catena dalla
qualità comprovata

TRATTAMENTO DEI RIFIUTI

35, rue des Bas-Trévois
CS 90104 - 10003 Troyes Cedex - France
Tél : +33 (0)3 25 76 29 50 - Fax : +33 (0)3 25 80 31 62
web : www.sedis.com - e-mail : <https://sedis.com/contact>

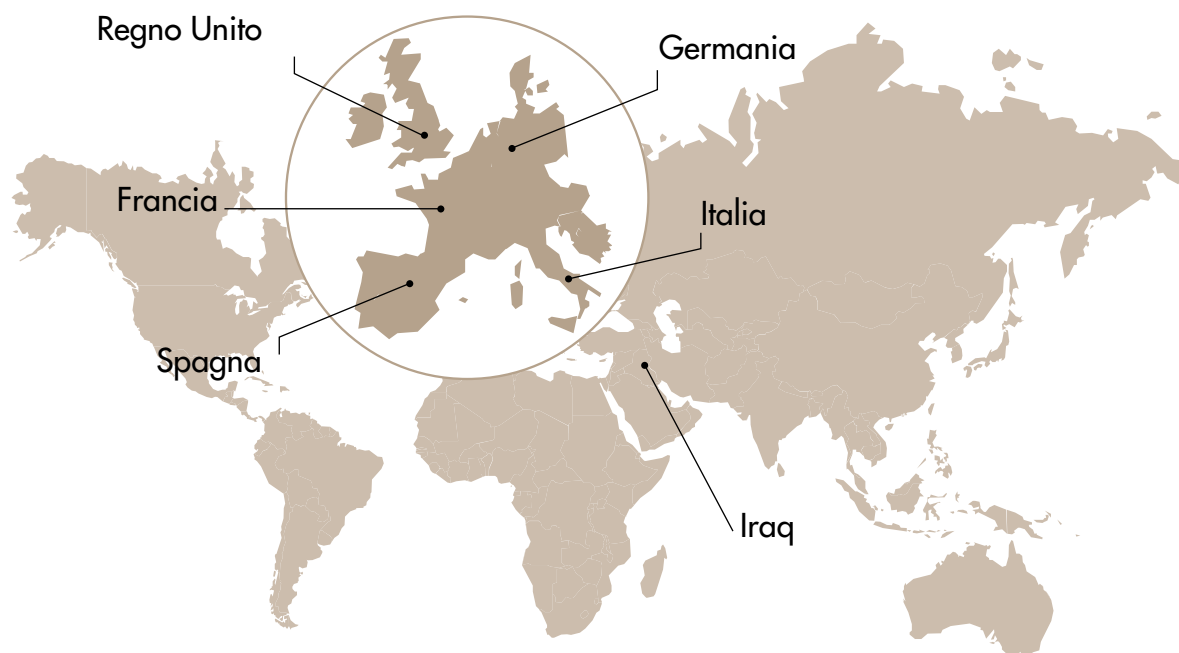

Da molti anni SEDIS mette il proprio know-how al servizio degli impianti di trattamento dei rifiuti.



Trattamento dei rifiuti domestici



Lavorazione del cartone

Catene DELTA®

Per condizioni estreme di utilizzo



Antiusura: DELTA® HR

- > In ambiente abrasivo, alta velocità, manutenzione casuale
- > Grazie ad un trattamento termochimico esclusivo SEDIS, le articolazioni delle catene DELTA® HR raggiungono una durezza estremamente elevata di 1800 HV.
- > Controllo del coefficiente di attrito

Anti allungamento

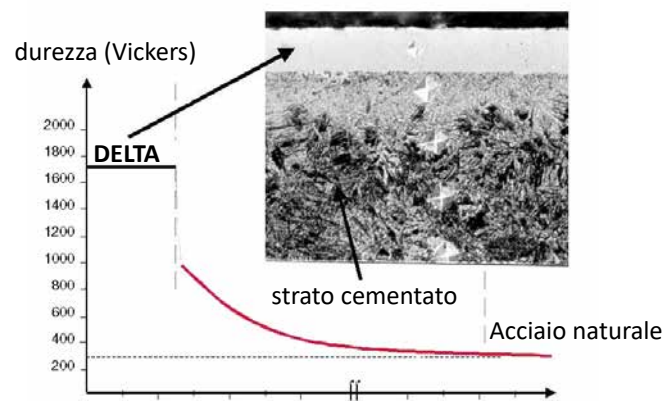

Anti-corrosione: DELTA® Titanium 2

- > TRATTAMENTO GARANTITO AL 100% SENZA CROMO 6
- > Catena antiusura e anticorrosione: DELTA® TITANIUM 2
- > Elevata resistenza meccanica: nessun infragilimento da idrogeno
- > Omologazione: NO HEAVY METALS conformemente alla legislazione europea (direttive 2000/53/CE e 2002/95/CE)

Anti-corrosione

Nebbia salina secondo ASTM B117

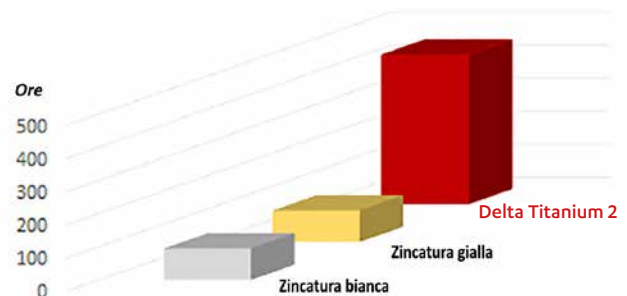

Non richiede manutenzione : DELTA® VERTE®

(100% ECOLOGICO)

- > Nessun inquinamento dei prodotti trasportati
- > Costi di manutenzione eliminati
- > Senza lubrificante
- > Funziona in acqua
- > Applicazioni ad alta e bassa temperatura

Senza lubrificante

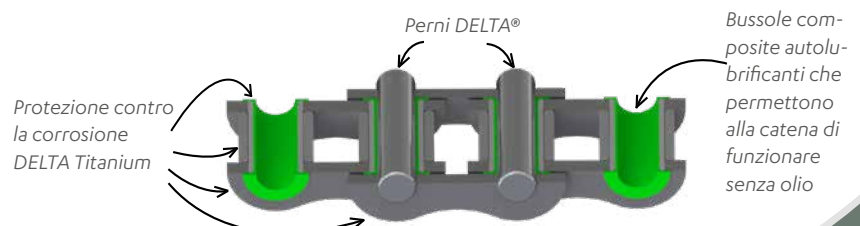

Catene di trasmissione - Gamma Delta® HR

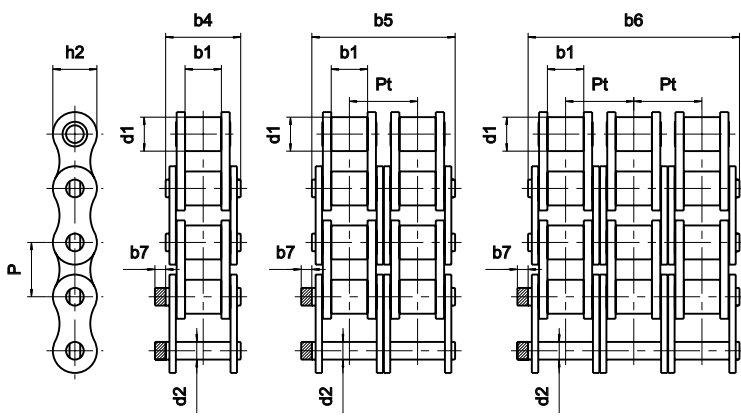

CATENA		DIMENSIONI GENERALI (mm)								RESISTENZA ALLA TRAZIONE			MAGLIE DI GIUNZIONE								
ISO 606	SEDIS	Passo in mm P	Ø rullo d1	Tra piastre interne b1	Larghezza su perni ribaditi b4	Ø perno d2	Altezza piastra h2	Pt	b7	Norma ISO 606	min	med	n°200	n°205	n°206	n°208	n°209	n°216	n°217	n°221	
BS SEMPLICE																					
08B-1	7ND	12,7	8,51	7,75	16,6	4,45	11,8		1,5	17,8	18,2	20,4	✓	✓	✓				✓	✓	
10B-1	11ND	15,875	10,16	9,65	19	5,08	13,7		1,5	22,2	23	27,2	✓	✓	✓				✓	✓	
12B-1	13ND	19,05	12,07	11,68	22,3	5,72	16,2		1,5	28,9	30,5	34,8	✓	✓	✓				✓	✓	
16B-1	15TD	25,4	15,88	17,02	35,1	8,28	20,8		3	60	75	87	✓	✓	✓	✓			✓	✓	
20B-1	17TD	31,75	19,05	19,56	40,5	10,19	25,4		6,1	95	110	119	✓	✓	✓	✓	✓		✓	✓	
24B-1	18TD	38,1	25,4	25,4	53,1	14,63	32,3		6,6	160	180	198	✓	✓	✓	✓	✓		✓	✓	
28B-1	20TD	44,45	27,94	30,95	65,1	15,9	37		7,4	200	235	251,5	✓	✓	✓	✓	✓		✓	✓	
32B-1	22TD	50,8	29,21	30,99	63,6	17,81	42,3		7,9	250	300	321	✓	✓	✓	✓	✓		✓	✓	
BS DOPPIA																					
08B-2	207ND	12,7	8,51	7,75	30,6	4,45	11,8	13,92	1,5	31,1	36,4	40,8	✓	✓	✓				✓	✓	
10B-2	211ND	15,875	10,16	9,65	35,75	5,08	13,7	16,59	1,5	44,5	46	54,4	✓	✓	✓				✓	✓	
12B-2	213ND	19,05	12,07	11,68	41,8	5,72	16,2	19,46	1,5	57,8	61	69,5	✓	✓	✓				✓	✓	
16B-2	215TD	25,4	15,88	17,02	68	8,28	20,8	31,88	3	106	150	174	✓	✓	✓	✓			✓	✓	
20B-2	217TD	31,75	19,05	19,56	77	10,19	25,4	36,45	6,1	170	220	239,8	✓	✓	✓	✓	✓		✓	✓	
24B-2	218TD	38,1	25,4	25,4	101,8	14,63	32,3	48,36	6,6	280	360	396	✓	✓	✓	✓	✓		✓	✓	
28B-2	220TD	44,45	27,94	30,95	124,7	15,9	37	59,56	7,4	360	470	502,9	✓	✓	✓	✓	✓		✓	✓	
32B-2	222TD	50,8	29,21	30,99	122,8	17,81	42,3	58,55	7,9	450	600	642	✓	✓	✓	✓	✓		✓	✓	
BS TRIPLA																					
09B-3	307ND	12,7	8,51	7,75	44,6	4,45	11,8	13,92	1,5	44,5	54,6	61,2	✓	✓	✓				✓	✓	
10B-3	311ND	15,875	10,16	9,65	52,3	5,08	13,7	16,59	1,5	66,7	69	81,6	✓	✓	✓				✓	✓	
12B-3	313ND	19,05	12,07	11,68	61,4	5,72	16,2	19,46	1,5	86,7	91,5	104,3	✓	✓	✓				✓	✓	
16B-3	315TD	25,4	15,88	17,02	99,9	8,28	20,8	31,88	3	160	225	261	✓	✓	✓	✓			✓	✓	
20B-3	317TD	31,75	19,05	19,56	113,5	10,19	25,4	36,45	6,1	250	330	359,7	✓	✓	✓	✓	✓		✓	✓	
24B-3	318TD	38,1	25,4	25,4	150,2	14,63	32,3	48,36	6,6	425	540	594	✓	✓	✓	✓	✓		✓	✓	
28B-3	320TD	44,45	27,94	30,95	184,6	15,9	37	59,56	7,4	530	705	754,4	✓	✓	✓	✓	✓		✓	✓	
32B-3	322TD	50,8	29,21	30,99	181,7	17,81	42,3	58,55	7,9	670	900	963	✓	✓	✓	✓	✓		✓	✓	
ANSI SEMPLICE																					
08A-1	40-1	12,7	7,93	7,85	16,3	3,98	11,5		1,5	13,9	18		✓	✓	✓	✓			✓	✓	
10A-1	50-1	15,875	10,15	9,55	20,45	5,09	13,7		1,5	21,8	28		✓	✓	✓	✓			✓	✓	
12A-1	60-1	19,05	11,91	12,65	25,4	5,96	16,2		4	31,3	38		✓	✓	✓	✓			✓	✓	
16A-1	80-1	25,4	15,88	15,87	32,8	7,94	20,8		4	55,6	62		✓	✓	✓	✓			✓	✓	
20A-1	100-1	31,75	19,05	19,05	39,6	9,53	25,4		6,1	87	99		✓	✓	✓	✓			✓	✓	
24A-1	120-1	38,1	22,22	25,4	49,6	11,10	35,2		6,6	125	140		✓	✓	✓	✓			✓	✓	
28A-1	140-1	44,45	25,4	25,4	53,5	12,7	42		7	170	178		✓	✓	✓	✓			✓	✓	
32A-1	160-1	50,8	28,58	31,75	64	14,27	48,2		7	223	228		✓	✓	✓	✓			✓	✓	
ANSI DOPPIA																					
08A-2	40-2	12,7	7,93	7,85	30,8	3,98	11,5	14,38	1,5	27,8	36		✓	✓	✓				✓	✓	
10A-2	50-2	15,875	10,15	9,55	38,9	5,09	13,7	18,1	1,5	43,6	56		✓	✓	✓				✓	✓	
12A-2	60-2	19,05	11,91	12,65	48,3	5,96	16,2	22,78	4	62,3	76		✓	✓	✓	✓			✓	✓	
16A-2	80-2	25,4	15,88	15,87	62,3	7,94	20,8	29,29	4	111,2	124		✓	✓	✓	✓			✓	✓	
20A-2	100-2	31,75	19,05	19,05	75,5	9,53	25,4	35,76	6,1	174	198		✓	✓	✓	✓			✓	✓	
24A-2	120-2	38,1	22,22	25,4	95,3	11,1	35,2	45,44	6,6	250	280		✓	✓	✓	✓			✓	✓	
28A-2	140-2	44,45	25,4	25,4	102,6	12,7	42	48,87	7	340	356		✓	✓	✓	✓			✓	✓	
32A-2	160-2	50,8	28,58	31,75	123	14,27	48,2	58,55	7	446	456		✓	✓	✓	✓			✓	✓	
ANSI TRIPLA																					
08A-3	40-3	12,7	7,93	7,85	45,3	3,98	11,5	14,38	1,5	41,7	54		✓	✓	✓				✓	✓	
10A-3	50-3	15,875	10,15	9,55	57	5,09	13,7	18,1	1,5	65,4	84		✓	✓	✓	✓			✓	✓	
12A-3	60-3	19,05	11,91	12,65	71,1	5,96	16,2	22,78	4	93,4	114		✓	✓	✓	✓			✓	✓	
16A-3	80-3	25,4	15,88	15,87	91,8	7,94	20,8	29,29	4	166,8	186		✓	✓	✓	✓			✓	✓	
20A-3	100-3	31,75	19,05	19,05	112,1	9,53	25,4	35,76	6,1	261	297		✓	✓	✓	✓			✓	✓	
24A-3	120-3	38,1	22,22	25,4	140,9	11,1	35,2	45,44	6,6	375	420		✓	✓	✓	✓			✓	✓	
28A-3	140-3	44,45	25,4	25,4	152,4	12,7	42	48,87	7	510	534		✓	✓	✓	✓			✓	✓	
32A-3	160-3	50,8	28,58	31,75	182	14,27	48,2	58,55	7	669	684		✓	✓	✓	✓			✓	✓	

Catene per rifiuti domestici

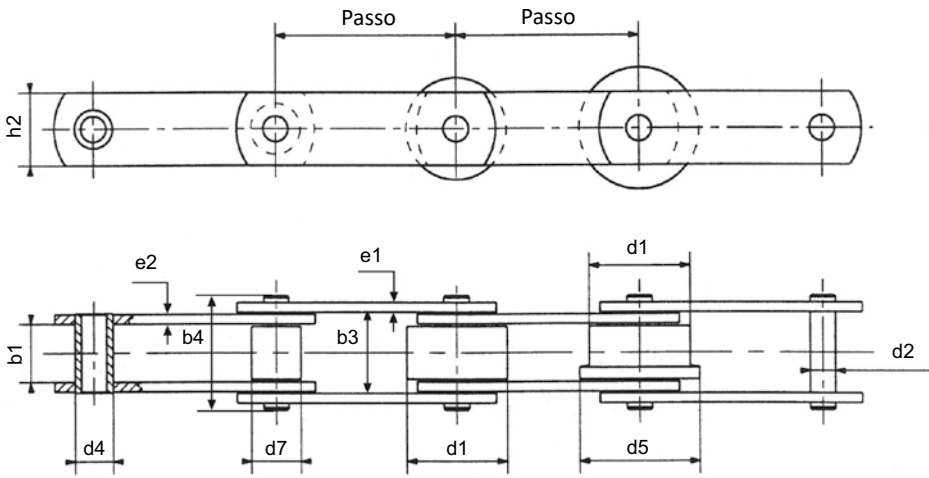

Le catene sono fornite con

- bussole,
- rulli,
- rulli grandi o flangiati.

I rulli sono in acciaio trattato.

Maglie di giunzione disponibili:

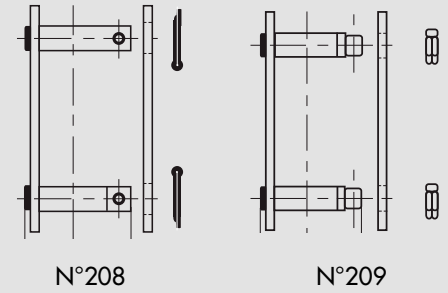

Dimensioni in mm

Catena	Passo (mm)										Larghezza Tra piastre interne	Larghezza Tra piastre esterne	Altezza piastra	Larghezza su perni ribaditi	Spessore piastre esterne	Spessore piastre interne	Ø perno	Ø bussola	Ø rullo	Ø rullo grande	Ø rullo flangiato	Resistenza alla trazione
	80	100	125	160	200	250	315	400	500	630												
M 112	*										31,0	45,7	40	62,0	5,0	6,0	15	21	30,0	60	75	112
M 160		*									36,0	52,7	50	72,0	6,0	7,0	18	25	36,0	70	86	160
M 224			*								42,0	60,8	60	81,2	6,0	8,0	21	30	42,0	85	105	224
M 315				*							47,6	70,8	70	94,2	8,0	10,0	25	36	50,0	100	125	315
M 450					*						55,5	82,9	80	112,5	10,0	12,0	30	42	60,0	120	150	450
M 630						*					66,0	97,0	100	131,5	12,0	15,0	36	50	70,0	140	170	630
M 900							*				78,0	113,0	120	153,0	14,0	16,0	44	60	85,0	170	210	900

Realizzabile

Consegna entro 15 giorni

* Solo per catene a bussole o a rulli

Aletta K corrispondenti

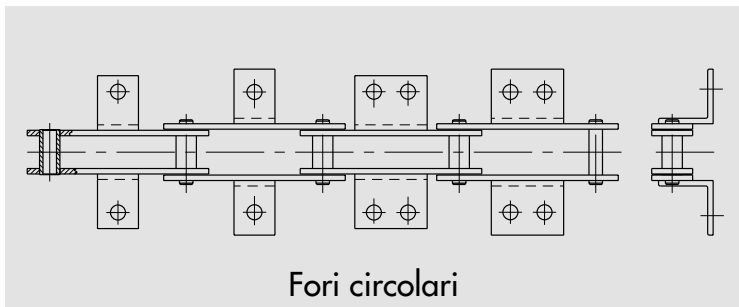

Fori circolari

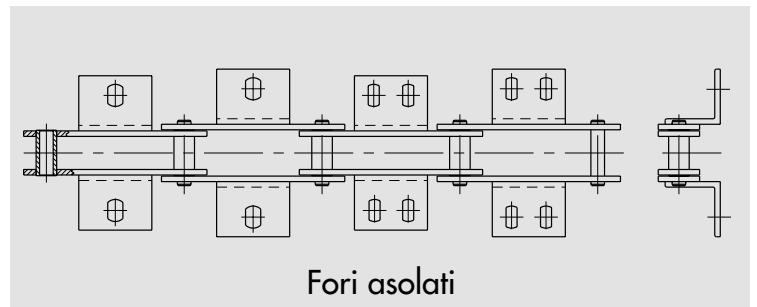

Fori asolati

Tutte queste catene sono disponibili nelle versioni:

- DELTA® HR
- DELTA® TITANIUM 2
- DELTA® VERTE®

Catene per rifiuti industriali ordinari (DIB)

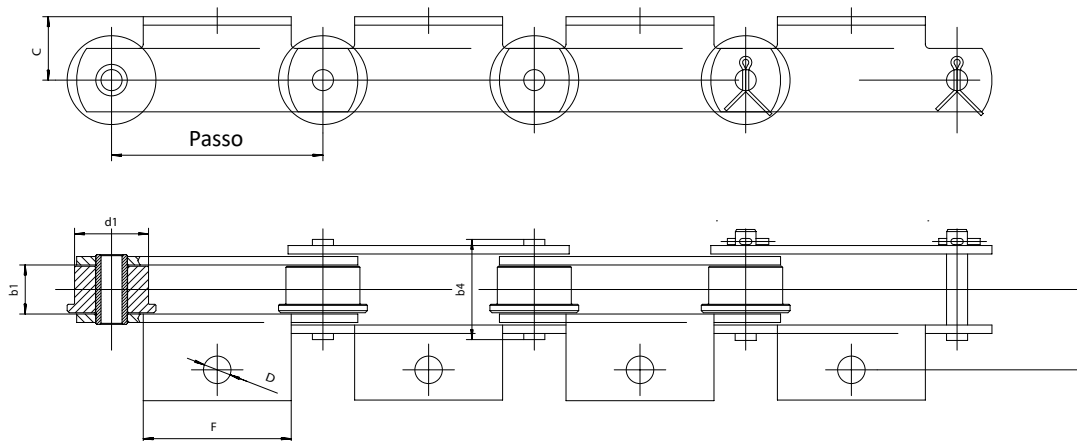

Passo	b1	b4	d1	A	C	D	F
100	22	45	40	46	24,5	13	70

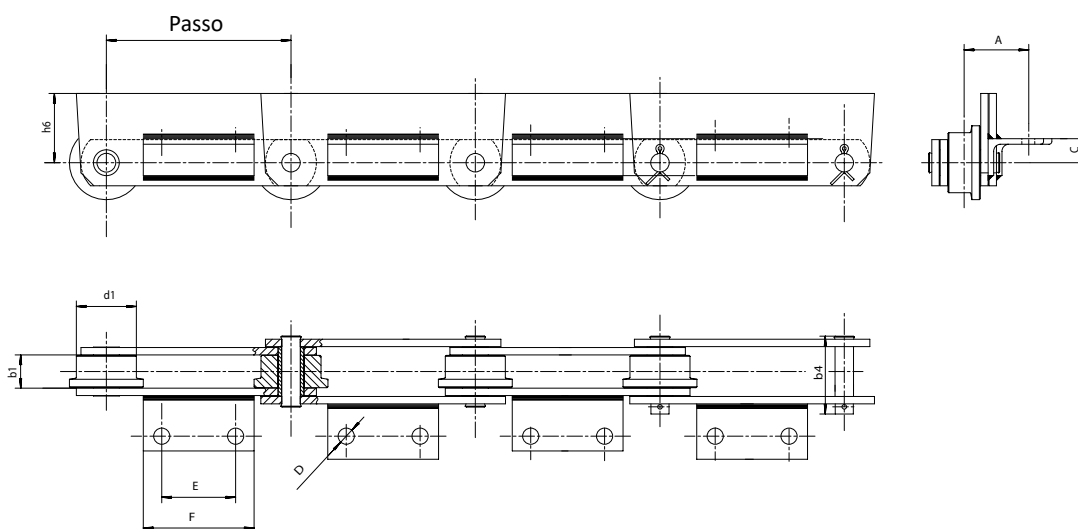

Passo	b1	b4	d1	h6	A	C	D	E	F
200	36	84,4	65	75	70	26	17,5	80	120



Catene per rifiuti industriali speciali (DIS)

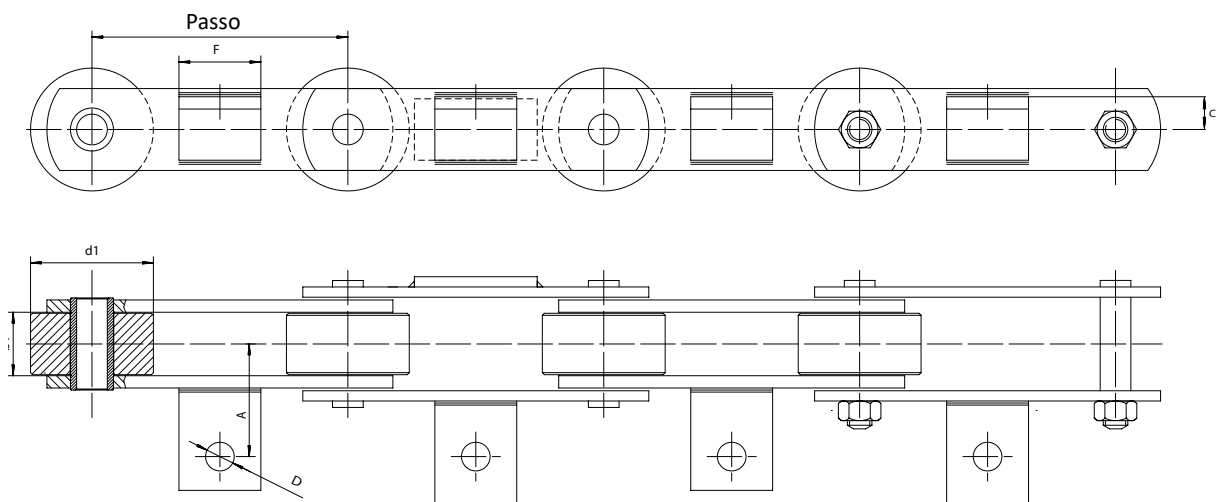

Passo	b1	d1	A	C	D	F
125	31min	60	59	16	10	65

Catene per il compostaggio dei rifiuti verdi

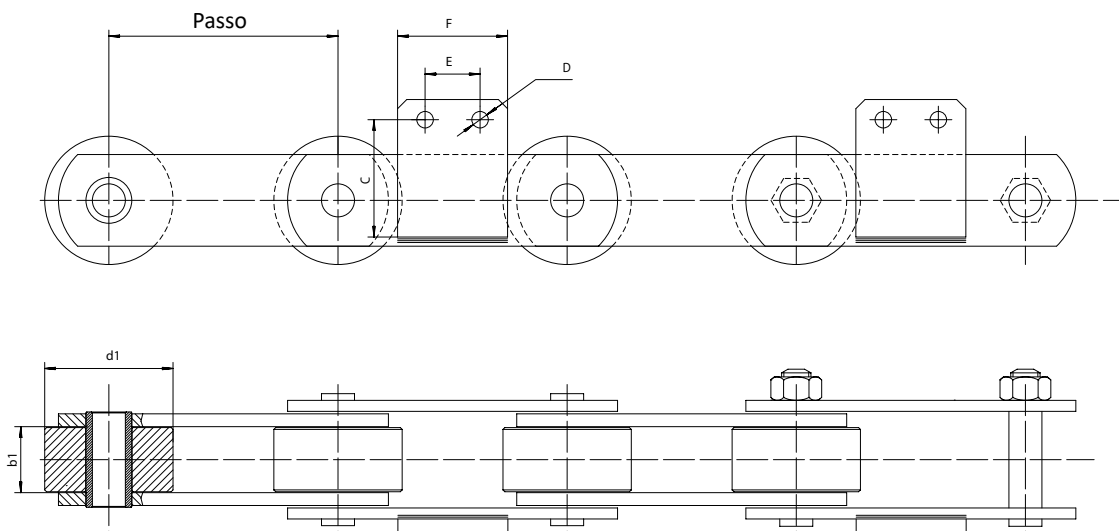

Passo	b1	d1	C	D	E	F
125	36min	70	64	9	30	60

Catene raschianti per materiali polverosi

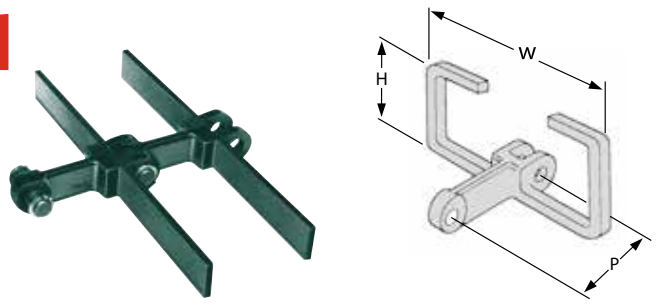

P	102	125	142	142	150	160	200	216	250	260
H	36	35	50	50	49	44,5	58	75	75	75
W	28	36	42	62	36	42	68	60	70	71

Pignoni - Dischi - Ruote

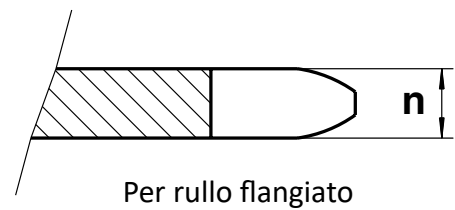
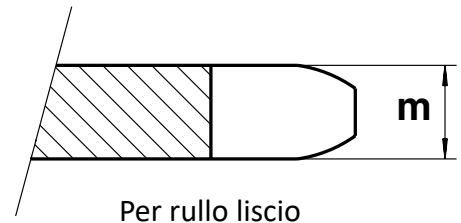
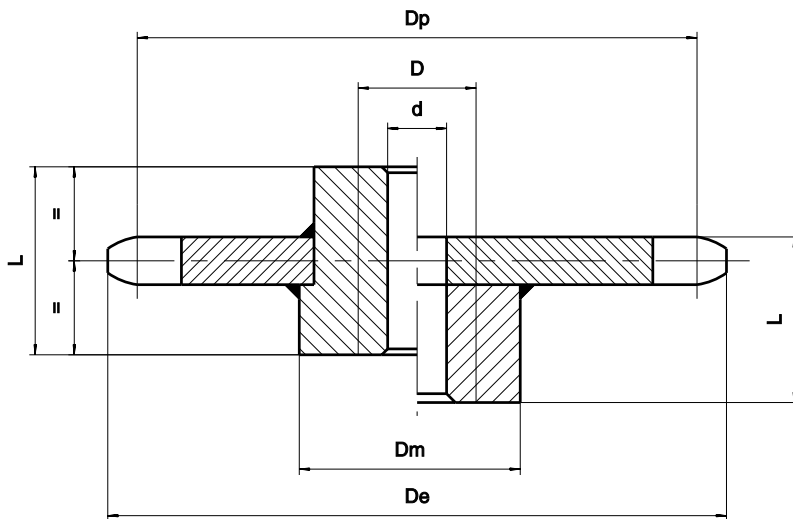

- > in acciaio INOX
- > in ACCIAIO
- > in GHISA

- > con mozzi forati
- > con mozzi rimovibili

Compatibili con le catene di questa brochure

